



# INSTALLATION INSTRUCTIONS

## PMP PHASE MONITOR RELAYS

November, 2008 Rev E (Replaces Rev D Dated April, 2005)

901-0000-108

**READ INSTRUCTIONS BEFORE INSTALLING OR OPERATING THIS DEVICE. KEEP FOR FUTURE REFERENCE.**

### Warning

Potentially hazardous voltages are present. Turn off all power supplying this equipment before connecting or disconnecting wiring.

### Installation & Setup

**NOTE:** Depending on the catalog number, not all PMP Series products come with all the knobs referenced below. Follow directions carefully.

- Mount the unit in a suitable enclosure. Use the appropriate socket listed on the product or shown below.
- (All except PMP120, PMP208-FA11 & PMP240-FA11) Set the NOMINAL VOLTAGE knob to the actual three-phase voltage. **NOTE:** DO NOT set nominal voltage with Line Voltage applied.
- (PMPU & PMP120 only) Set initial settings on the remaining knobs as follows: UNDERVOLTAGE, TIME DELAY ON UNDERVOLTAGE, and TIME DELAY RESTART to minimum (CCW); UNBALANCE to DISABLE (maximum CW).
- Connect the fused 3-phase line voltage to the appropriate terminals-see "Wiring Diagrams" below. A connection to the neutral is not required in Wye systems. DO NOT connect wires to the output terminals until later (Step 10). Plug the unit into the socket. **NOTE:** Fuses are optional at the discretion of the user--if used, recommended fuse size is 2A maximum.
- Apply Line Voltage. The LED indicator should illuminate GREEN and stay steady. If the LED illuminates RED OR AMBER, either steady or flashes, a fault condition exists and must be corrected-see Table below to determine actual fault. Check to see if all phases are present. REMOVE LINE VOLTAGE, and switch any two of the line voltage connections to insure the phase rotation is correct. Reapply line voltage to check for correct phase rotation. Check to see if line voltage is at least 95% of the nominal voltage, and no more than 110% of the nominal voltage.
- REMOVE LINE VOLTAGE for Steps 6-9. (PMPU & PMP120 only) Set the UNDERVOLTAGE dial. This setting should be the same as the minimum operating voltage for the equipment to be adequately protected.
- (PMPU & PMP120 only) Set the TIME DELAY ON UNDERVOLTAGE dial. This is the maximum time period that an undervoltage condition should be allowed to last. Too short a setting will cause nuisance tripping if there are momentary dips in the line voltage. Too long a setting could cause damage to the equipment. Note that the setting should be at least slightly longer than the time a 3-phase motor is drawing its inrush current. This will avoid nuisance tripping caused by the starting current.
- (PMPU & PMP120 only) Set the UNBALANCE dial. This setting should be the maximum allowable unbalance in phase voltage that the 3-phase system can tolerate. Too low of a setting can cause nuisance tripping. Too high of a setting may not adequately protect the system.
- (PMPU & PMP120 only) Set the TIME DELAY RESTART dial. This setting should be the time period required after a fault has been cleared before the relay is to energize.
- Connect the output terminals as shown in "Wiring Diagrams".
- When all connections have been made, apply Line Voltage. The LED indicator will illuminate GREEN steady, the internal relay will energize, and the 3-phase system will become operational. (All except PMP120, PMP208-FA11 & PMP240-FA11) **NOTE:** if LED alternately flashes Red-Amber, the NOMINAL VOLTAGE knob must be either adjusted slightly CCW for under 300V settings or slightly CW for settings greater than 300V.
- If the LED illuminates RED or AMBER, either steady or flashes, during regular operation, one of the five fault conditions has occurred (see "Fault Indication Code Table" right). REMOVE LINE VOLTAGE, and check for proper phase rotation, presence of all three phases, phase unbalance, and low or high voltage conditions. Correct if necessary. Re-energization is automatic upon correction of the fault condition unless using MANUAL RESET (PMPU & PMP120 only-see Step 13).
- (PMPU & PMP120 only) **MANUAL RESET:** To use this option, connect a normally closed (N.C.) momentary contact across terminals 6 & 7. After a fault has been cleared, the unit will not reset until this N.C. contact is momentarily opened. **NOTE:** This N.C. contact must be closed at power-up, or unit will operate in the automatic reset mode. Also, after power has been applied to this unit, the N.C. contact must be opened momentarily to reset the unit for normal operation.

LED Status	Indicator
Green Steady	Normal / Relay ON
Green Flashing	Power Up / Restart Delay
Red Steady	Unbalance
Red Flashing	Undervoltage / Overvoltage
Amber Steady	Reversal
Amber Flashing	Loss
Green / Red Alternating	Undervoltage / Overvoltage Trip Pending
Red / Amber Alternating	Nominal Voltage Set Error*

\* Does not apply to single voltage products.

### Wiring Diagrams

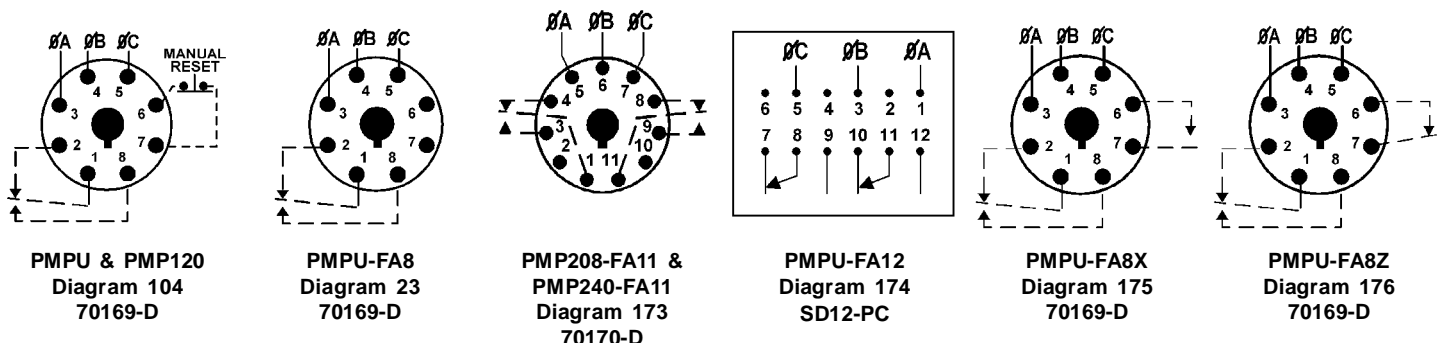

**Warranty**--All products manufactured by Macromatic are warranted to be free from defects in workmanship or material under normal service and use for a period of Five (5) Years from date of manufacture.